

**PHARMACOPOEIAL DISCUSSION GROUP**

**REVISION 1**

**G02**

**Bulk density and tapped density of powders**

*It is understood that sign-off covers the technical content of the draft and each party will adapt it as necessary to conform to the usual presentation of the pharmacopoeia in question; such adaptation includes stipulation of the particular pharmacopoeia's reference materials and general chapters.*

**European Pharmacopoeia**

Signature

Name

Date

Leslie

LESITEL

070608

**Japanese Pharmacopoeia**

Signature

Name

Date

Shigenori Imai

for Toshiro Nakagaki

05 June, 2008

**United States Pharmacopeia**

Signature

Name

Date

Darrell R. Asermeyer

DARRELL R. ASERMEYER 05 June, 2008



---

1  
2  
3  
4 **BULK DENSITY AND TAPPED DENSITY OF POWDERS**  
5  
6

7 **Bulk density**  
8

9 The bulk density of a powder is the ratio of the mass of an untapped powder sample and  
10 its volume including the contribution of the interparticulate void volume. Hence, the bulk  
11 density depends on both the density of powder particles and the spatial arrangement of  
12 particles in the powder bed. The bulk density is expressed in grams per milliliter (g/ml)  
13 although the international unit is kilogram per cubic meter ( $1 \text{ g/ml} = 1000 \text{ kg/m}^3$ )  
14 because the measurements are made using cylinders.

15 It may also be expressed in grams per cubic centimeter ( $\text{g/cm}^3$ ).

16 The bulking properties of a powder are dependent upon the preparation, treatment and  
17 storage of the sample, i.e. how it was handled. The particles can be packed to have a range  
18 of bulk densities and, moreover, the slightest disturbance of the powder bed may result  
19 in a changed bulk density. Thus, the bulk density of a powder is often very difficult to  
20 measure with good reproducibility and, in reporting the results, it is essential to specify  
21 how the determination was made.  
22

23 The bulk density of a powder is determined by measuring the volume of a known mass of  
24 powder sample, that may have been passed through a screen, into a graduated cylinder  
25 (Method 1), or by measuring the mass of a known volume of powder that has been passed  
26 through a volumeter into a cup (Method 2) or a measuring vessel (Method 3).

27 *Method 1 and method 3 are favoured.*  
28

29 **METHOD 1: MEASUREMENT IN A GRADUATED CYLINDER**  
30

31 *Procedure.* Pass a quantity of powder sufficient to complete the test through a sieve with  
32 apertures greater than or equal to 1.0 mm, if necessary, to break up agglomerates that  
33 may have formed during storage; this must be done gently to avoid changing the nature of  
34 the material. Into a dry graduated cylinder of 250 ml (readable to 2 ml), gently introduce,  
35 without compacting, approximately 100 g of the test sample ( $m$ ) weighed with 0.1 per  
36 cent accuracy. Carefully level the powder without compacting, if necessary, and read the  
37 unsettled apparent volume ( $V_0$ ) to the nearest graduated unit. Calculate the bulk density  
38 in g per ml by the formula  $m/V_0$ . Generally, replicate determinations are desirable for the  
39 determination of this property.

40 If the powder density is too low or too high, such that the test sample has an untapped  
41 apparent volume of either more than 250 ml or less than 150 ml, it is not possible to use  
42 100 g of powder sample. Therefore, a different amount of powder has to be selected as test  
43 sample, such that its untapped apparent volume is 150 ml to 250 ml (apparent volume  
44 greater than or equal to 60 per cent of the total volume of the cylinder); the mass of the  
45 test sample is specified in the expression of results.

46 For test samples having an apparent volume between 50 ml and 100 ml a 100 ml cylinder  
47 readable to 1 ml can be used; the volume of the cylinder is specified in the expression  
of results.

1  
2 **METHOD 2: MEASUREMENT IN A VOLUMETER**

3 *Apparatus.* The apparatus<sup>(1)</sup> (Figure 1) consists of a top funnel fitted with a 1.0 mm screen.  
4 The funnel is mounted over a baffle box containing four glass baffle plates over which the  
5 powder slides and bounces as it passes. At the bottom of the baffle box is a funnel that  
6 collects the powder and allows it to pour into a cup mounted directly below it. The cup  
7 may be cylindrical ( $25.00 \pm 0.05$  ml volume with an inside diameter of  $30.00 \pm 2.00$  mm) or  
8 a square ( $16.39 \pm 2.00$  mm volume with inside dimensions of  $25.4 \pm 0.076$  mm).  
9

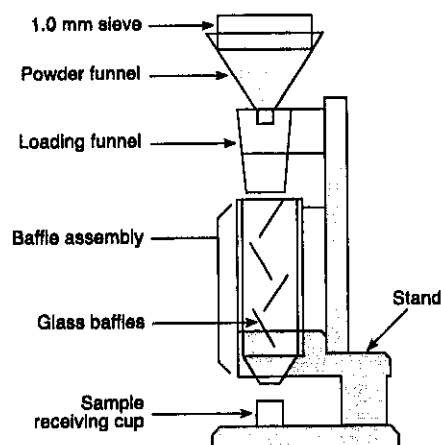

23 **Figure 1. Volumeter**

24 *Procedure.* Allow an excess of powder to flow through the apparatus into the sample  
25 receiving cup until it overflows, using a minimum of  $25 \text{ cm}^3$  of powder with the square cup  
26 and  $35 \text{ cm}^3$  of powder with the cylindrical cup. Carefully, scrape excess powder from the  
27 top of the cup by smoothly moving the edge of the blade of a spatula perpendicular to and  
28 in contact with the top surface of the cup, taking care to keep the spatula perpendicular to  
29 prevent packing or removal of powder from the cup. Remove any material from the side of  
30 the cup and determine the mass ( $M$ ) of the powder to the nearest 0.1 per cent. Calculate  
31 the bulk density in g per ml by the formula  $M/V_0$  in which  $V_0$  is the volume of the cup and  
32 record the average of 3 determinations using 3 different powder samples.  
33

34 **METHOD 3. MEASUREMENT IN A VESSEL**

35 *Apparatus.* The apparatus consists of a 100 ml cylindrical vessel of stainless steel with  
36 dimensions as specified in Figure 2.  
37

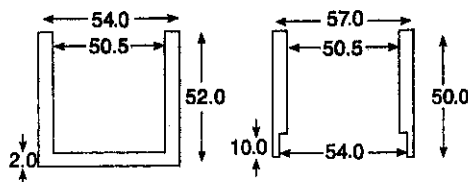

**Figure 2. - Measuring vessel (left) and cap (right) - Dimensions in mm**

(1) The apparatus (the Scott Volumeter) conforms to the dimensions in ASTM 329 90.

---

1  
2 *Procedure.* Pass a quantity of powder sufficient to complete the test through a 1.0 mm  
3 sieve, if necessary, to break up agglomerates that may have formed during storage and  
4 allow the obtained sample to flow freely into the measuring vessel until it overflows.  
5 Carefully scrape the excess powder from the top of the vessel as described for Method 2.  
6 Determine the mass ( $M_0$ ) of the powder to the nearest 0.1 per cent by subtraction of  
7 the previously determined mass of the empty measuring vessel. Calculate the bulk  
8 density (g/ml) by the formula  $M_0/v$  and record the average of 3 determinations using  
9 3 different powder samples.

## 11 Tapped density

13 The tapped density is an increased bulk density attained after mechanically tapping a  
14 container containing the powder sample.

15 The tapped density is obtained by mechanically tapping a graduated measuring cylinder or  
16 vessel containing the powder sample. After observing the initial powder volume or mass,  
17 the measuring cylinder or vessel is mechanically tapped, and volume or mass readings  
18 are taken until little further volume or mass change is observed. The mechanical tapping  
19 is achieved by raising the cylinder or vessel and allowing it to drop, under its own mass,  
20 a specified distance by either of 3 methods as described below. Devices that rotate the  
21 cylinder or vessel during tapping may be preferred to minimize any possible separation of  
22 the mass during tapping down.  
23

### 24 METHOD 1

25 *Apparatus.* The apparatus (Figure 3) consists of the following:

- 26 – a 250 ml graduated cylinder (readable to 2 ml) with a mass of  $220 \pm 44$  g,
- 27
- 28 – a settling apparatus capable of producing, in 1 min, either nominally  $250 \pm 15$  taps from  
29 a height of  $3 \pm 0.2$  mm, or nominally  $300 \pm 15$  taps from a height of  $14 \pm 2$  mm. The  
30 support for the graduated cylinder, with its holder, has a mass of  $450 \pm 10$  g.  
31  
32  
33  
34  
35  
36  
37  
38  
39  
40  
41  
42  
43  
44  
45  
46  
47

1  
2  
3  
4  
5  
6  
7  
8  
9  
10  
11  
12  
13  
14  
15  
16  
17  
18  
19  
20  
21  
22  
23  
24  
25  
26  
27  
28  
29  
30  
31  
32  
33  
34  
35  
36  
37  
38  
39  
40  
41  
42  
43  
44  
45  
46  
47

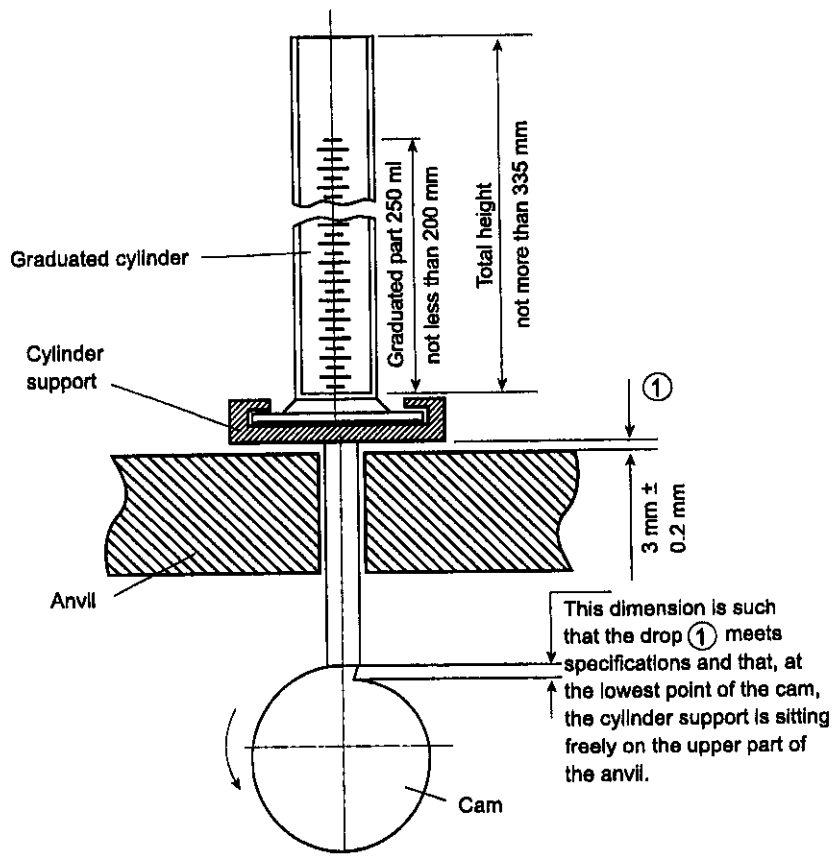

Figure 3

*Procedure.* Proceed as described above for the determination of the bulk volume ( $V_0$ ). Secure the cylinder in the holder. Carry out 10, 500 and 1250 taps on the same powder sample and read the corresponding volumes  $V_{10}$ ,  $V_{500}$  and  $V_{1250}$  to the nearest graduated unit. If the difference between  $V_{500}$  and  $V_{1250}$  is less than 2 ml,  $V_{1250}$  is the tapped volume. If the difference between  $V_{500}$  and  $V_{1250}$  exceeds 2 ml, repeat in increments such as 1250 taps, until the difference between succeeding measurements is less than 2 ml. Fewer taps may be appropriate for some powders, when validated. Calculate the tapped density (g/ml) using the formula  $m/V_f$  in which  $V_f$  is the final tapped volume. Generally, replicate determinations are desirable for the determination of this property. Specify the drop height with the results.

If it is not possible to use a 100 g test sample, use a reduced amount and a suitable 100 ml graduated cylinder (readable to 1 ml) weighing  $130 \pm 16$  g and mounted on a holder weighing  $240 \pm 12$  g. The modified test conditions are specified in the expression of the results.

## METHOD 2

*Procedure.* Proceed as directed under Method 1 except that the mechanical tester provides a fixed drop of  $3 \pm 0.2$  mm at a nominal rate of 250 taps per minute.

---

1  
2 METHOD 3  
3

4 *Procedure.* Proceed as described in the method for measuring the bulk density using the  
5 measuring vessel equipped with the cap shown in Figure 2. The measuring vessel with  
6 the cap is lifted 50-60 times per minute by the use of a suitable tapped density tester.  
7 Carry out 200 taps, remove the cap and carefully scrape excess powder from the top of  
8 the measuring vessel as described in Method 3 for measuring the bulk density. Repeat  
9 the procedure using 400 taps. If the difference between the 2 masses obtained after 200  
10 and 400 taps exceeds 2 per cent, carry out a test using 200 additional taps until the  
11 difference between succeeding measurements is less than 2 per cent. Calculate the tapped  
12 density (g/ml) using the formula  $M_t/100$  where  $M_t$  is the mass of powder in the measuring  
13 vessel. Record the average of 3 determinations using 3 different powder samples.  
14

15  
16 Measures of powder compressibility  
17

18 Because the interparticulate interactions influencing the bulking properties of a powder  
19 are also the interactions that interfere with powder flow, a comparison of the bulk and  
20 tapped densities can give a measure of the relative importance of these interactions in a  
21 given powder. Such a comparison is often used as an index of the ability of the powder to  
22 flow, for example the Compressibility Index or the Hausner Ratio.  
23

24 The *Compressibility Index* and Hausner Ratio are measures of the propensity of a powder  
25 to be compressed as described above. As such, they are measures of the powder ability  
26 to settle and they permit an assessment of the relative importance of interparticulate  
27 interactions. In a free-flowing powder, such interactions are less significant, and the  
28 bulk and tapped densities will be closer in value. For poorer flowing materials, there  
29 are frequently greater interparticulate interactions, and a greater difference between  
30 the bulk and tapped densities will be observed. These differences are reflected in the  
31 *Compressibility Index* and the Hausner Ratio.  
32

33 *Compressibility Index :*  
34

35  
36 
$$\frac{100 (V_0 - V_f)}{V_0}$$
  
37  
38

39  
40  $V_0$  = unsettled apparent volume,  
41  $V_f$  = final tapped volume.  
42

43  
44  
45  
46  
47

1  
2  
3  
4  
5  
6  
7  
8  
9  
10  
11  
12  
13  
14  
15  
16  
17  
18  
19  
20  
21  
22  
23  
24  
25  
26  
27  
28  
29  
30  
31  
32  
33  
34  
35  
36  
37  
38  
39  
40  
41  
42  
43  
44  
45  
46  
47

---

Hausner Ratio:

$$\frac{V_0}{V_f}$$

Depending on the material, the compressibility index can be determined using  $V_{10}$  instead of  $V_0$ .